

OVENS

VULCAN**VC5G SERIES
SINGLE DECK GAS CONVECTION OVEN
WITH REMOVABLE DOORS****SPECIFICATIONS**

Single section, gas convection oven Vulcan Model No. VC5GD. Stainless steel front, sides and top. Painted legs. Independently operated removable stainless steel doors with double pane windows. Non-sag insulation applied to the top, rear and sides. Porcelain enamel on steel oven interior measures 29"w x 22 $\frac{1}{8}$ "d x 20"h. One interior oven light. Five nickel plated oven racks measure 28 $\frac{1}{4}$ " x 20 $\frac{1}{2}$ " with grab-and-go front cut out. Eleven position nickel plated rack guides with positive rack stops. One 50,000 BTU/hr. burner. Electronic spark igniter. Furnished with a two speed $\frac{1}{2}$ H.P. oven blower-motor. Oven cool switch for rapid cool down. 120 volt, 60 Hz, 1 ph power supply required. 6' cord and plug supplied. 7.7 amps total draw.

Exterior Dimensions:

40"w x 39 $\frac{1}{4}$ "d (includes motor & door handles) 36 $\frac{1}{2}$ "d (includes motor only) x 54 $\frac{3}{4}$ "h on 23 $\frac{3}{4}$ " legs with feet. 23 $\frac{3}{4}$ " legs can be adjusted an additional 1" in length. Legs with casters are adjustable from 28" to 29 $\frac{1}{8}$ " in length.

CSA design certified. NSF listed.

**SPECIFY TYPE OF GAS WHEN ORDERING.
SPECIFY ALTITUDE WHEN ABOVE 2,000 FT.**

- VC5GD** Solid state temperature dial controls adjust from 150° to 500°F with digital display enhancement. 5-hour timer with audible alarm.

STANDARD FEATURES

- Independently operated lift-off stainless steel doors with double pane windows.
- On-board diagnostics for easy servicing
- Stainless steel front, sides and top.
- Five nickel plated grab-and-go oven racks with eleven rack positions.
- Painted legs.
- 5-hour timer with digital display enhancement.
- Cool-to-the-touch handles.
- 50,000 BTU/hr. burner.
- Electronic spark igniter.
- $\frac{1}{2}$ H.P. two speed oven blower-motor. 120/60/1 with 6' cord and plug. 7.7 amps total draw.
- Oven cool switch for rapid cool down.
- Porcelain enamel on steel oven interior.
- $\frac{3}{4}$ " rear gas connection with combination gas valve / pressure regulator and safety solenoid system.
- One year limited parts and labor warranty.
- Three year limited warranty on doors.

OPTIONS

- Stainless steel legs.
- Casters.
- Second year extended limited parts and labor warranty.

ACCESSORIES

- Stainless steel open stand with adjustable rack supports, stainless steel shelf and choice of adjustable feet or casters.
- Stainless steel rear enclosure.
- Extra oven rack(s).
- Rack hanger.
- Stainless steel drip pan.
- Flexible gas hose with quick disconnect and restraining device. Consult price book for available sizes.
- Down draft flue diverter for direct vent connection.

VULCAN

a division of ITW Food Equipment Group LLC

P.O. Box 696 ■ Louisville, KY 40201 ■ Toll-free: 1-800-814-2028 ■ Local: 502-778-2791 ■ Quote & Order Fax: 1-800-444-0602



VC5G SERIES SINGLE DECK GAS CONVECTION OVEN WITH REMOVABLE DOORS

INSTALLATION INSTRUCTIONS

1. A combination gas valve/pressure regulator and safety solenoid system is included in this unit. Natural gas is 5.0" W.C., Propane gas is 10.0" W.C.
2. An adequate ventilation system is required for commercial cooking equipment. Information may be obtained by writing to the National Fire Protection Association, Batterymarch Park, Quincy, MA 02289. When writing, refer to NFPA No. 96.
3. These units are manufactured for installation in accordance with ANSZ223.1 (latest edition), National Fuel Gas Code. Copies may be obtained from American Gas Association Inc., Accredited Standards Committee Z223, 400 N. Capitol St. NW, Washington, DC 20001 or the Secretary Standards Council, NFPA, 1 Batterymarch Park, Quincy, MA 02169-7471.
4. Clearances:

Clearances:	Combustible	Non-combustible
Rear	0"	0"
Right Side	2"	0"
Left Side	1"	0"
5. This appliance is manufactured for commercial installation only and is not intended for home use.

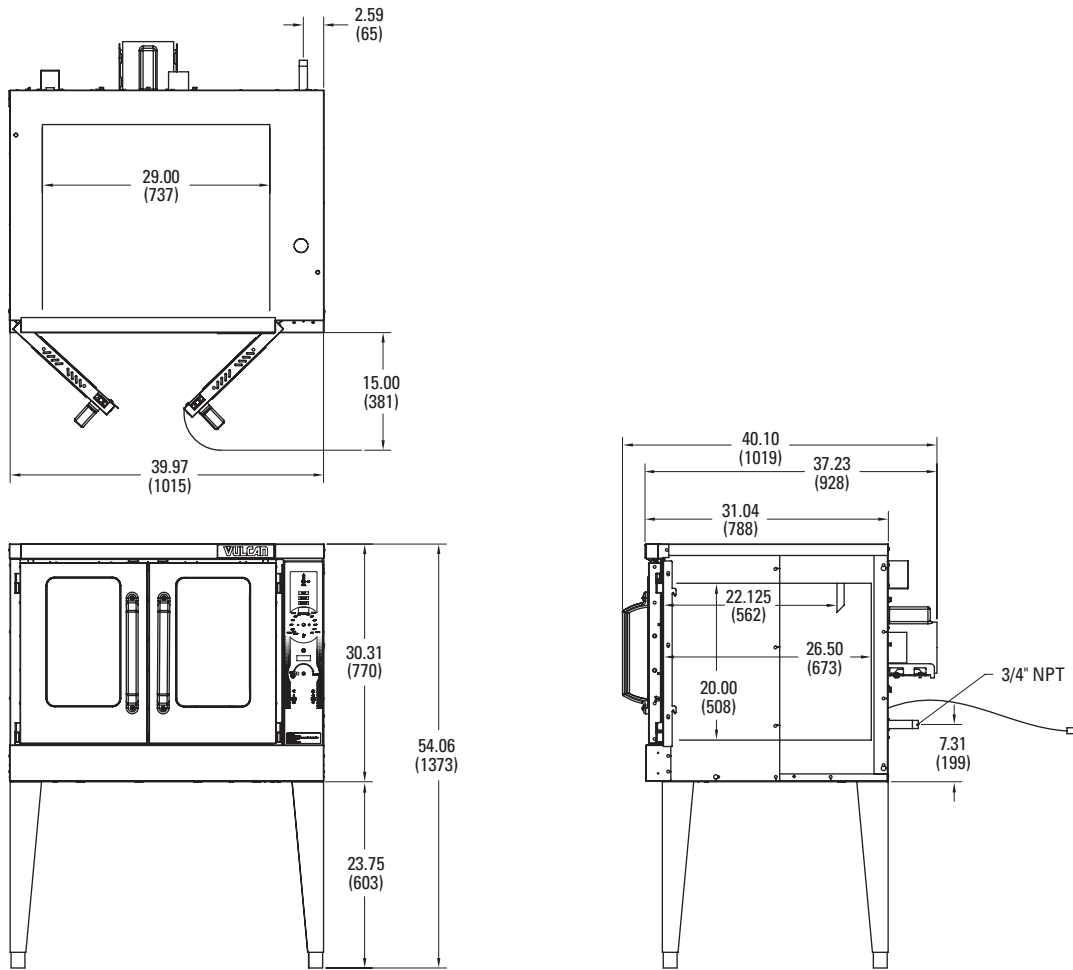

MODEL NO.	WIDTH	DEPTH (INCLUDES HANDLES)	HEIGHT	BTU/HR. PER OVEN	TOTAL BTU/HR.	ELECTRICAL	WEIGHT			
							WITH SKID & PACKAGING		WITHOUT SKID & PACKAGING	
							LBS.	KG	LBS.	KG
VC5G	40"	39 ¹ / ₄ "	54"	50,000	50,000	120/60/1	389	176	333	151



a division of ITW Food Equipment Group LLC

P.O. Box 696 ■ Louisville, KY 40201 ■ Toll-free: 1-800-814-2028 ■ Local: 502-778-2791 ■ Quote & Order Fax: 1-800-444-0602